

# Fasti-NORM CLINCHING FASTENERS

NORM weldless clinching fasteners are developed to provide a very strong torque resistance with high axial clamping loads without performing any welding operation.



It's clean and safe. No harmful gases are released during the assembly.



There is no lack of heat or energy. Sheet metal and fastener are not required to be melted together, thus there is no need for heating and cooling or annealing the assembly parts after the mounting operation.

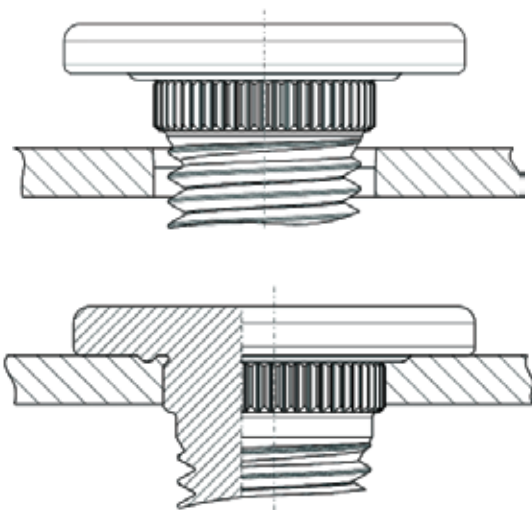

It is fast. It can be applied mechanically just in seconds. Once the fastener is mounted, the connection can operate for years.



Excessive torque resistance: The weldless clinching fastener mounts the assembly parts with a very economic and fast way without deteriorating micro crystal structure. It provides a very strong connection.



It mechanically creates a permanent joining without causing any metallurgical change in assembled parts.



#### for more information:

10007 Sk. No: 1/1 A.O.S.B. Çiğli-İZMİR Turkey  
Phone: +90 232 376 76 10 Fax: +90 232 376 76 13

info@normcivata.com  
www.norm-fasteners.com.tr

# TEST and APPLICATION CENTER



Perthometer



Profile Projection



Video Projection

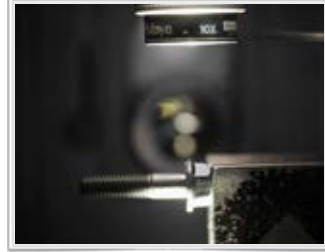

Spectrometer



Mechanical & Statical Testers



Optical Microscopes



Stereo - zoom Microscopes



Molding, Cutting and Polishing Equipments



Thermal Camera



Hardness Measurement Testers



Coordinate Measuring Machine (CMM)



Fatigue Tester



Torque - Tension Tester



Bi - axial Vibration Tester

for more information:

10007 Sk. No: 1/1 A.O.S.B. Çiğli-İZMİR Turkey  
Phone: +90 232 376 76 10 Fax: +90 232 376 76 13

info@normcivata.com  
www.norm-fasteners.com.tr